

# QPDM Partial Discharge Monitoring Solutions for Transformers and Small GIS



## Qualitrol® QPDM Series

---

Partial Discharge Monitoring Systems for Transformers and Gas Insulated Switch Gear

Protect against costly failures, extend asset life, enable Condition Based Maintenance

Qualitrol® Company LLC

---



# The Value of Partial Discharge Monitoring

Understanding asset health is fundamental to optimizing asset life, asset utilization, and maintenance resources. Partial Discharge (PD) activity is a key measure of asset health in both Transformers and Gas Insulated Switchgear (GIS). Since PD is a leading indicator of most causes of failure in Transformers and GIS, monitoring it, or ideally a lack of it, allows users to address issues prior to escalation and deploy valuable resources where they are needed most.

DMS partial discharge monitoring systems enable customers with a wide range of options for identifying and categorizing partial discharge.

This allows them to make informed decisions about the appropriate course of action to take optimizing asset utilization and prolonging asset life.

Back by a team of industry experts, Qualitrol offers expert analysis of PD signals, thereby alleviating the customer of the burden of making sense of enormous amounts of unfamiliar data. By interpreting PD data and developing actionable insights users can fully unlock the value of partial discharge monitoring.

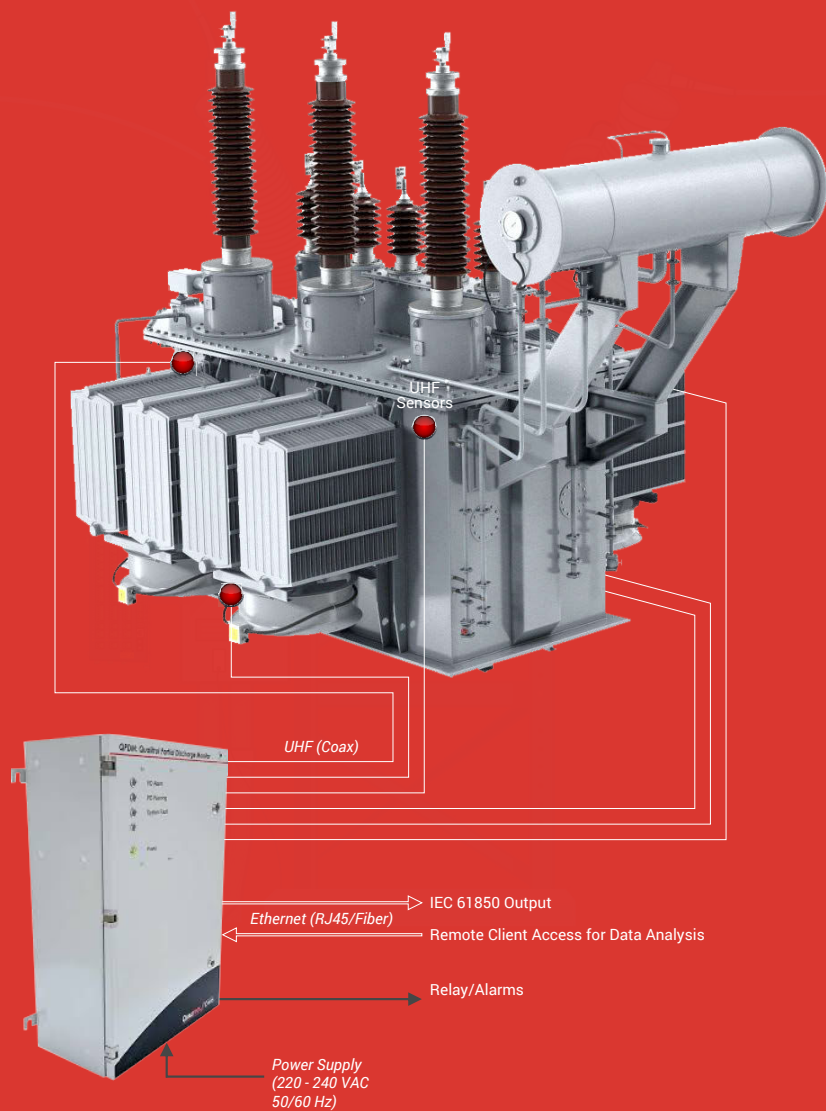

---

## A SINGLE BOX PD SOLUTION

The QPDM is a continuous, on-line monitoring solution capable of monitoring up to 6 UHF sensors for partial discharge. It monitors PD activity in real time, detecting defects so that users can make informed maintenance and asset management decisions. This next generation system with higher sensitivity and wider dynamic range provides accurate, reliable and reproducible measurements even under the most difficult environmental conditions.





The QPDM system works by capturing signals from UHF sensors and filtering out interference (noise) from the environment. The data captured is then analyzed by an ANN (Artificial Neural Network) proprietary to Qualitrol based off of millions of PD signal captured over 25+ years from utilities and various brands of assets around the world. Algorithms identify if the signals are PD, and if so, the defect type. This information along with amplitude, discharge rate and longevity serves as the foundation for analysis and action.

The QPDM enclosure is designed for hospitable and harsh environments and has 4 LED indicators to provide local indication of alarm and system faults. However, its remote client software allows users to configure and monitor the system from any computer on the same network. 4 SCADA/SCS alarm contacts enhance the visibility of alarms, outside of the QPDM itself.

  
**Predict**  
costly asset failures

Continuous, real-time PD monitoring ensures early indication of faults and possible asset failure

  
**Health**  
assessments

PD data can be correlated and assessed with data from multiple monitors to provide a health assessment of the asset

  
**Extend**  
asset life cycles

Correlation of PD activity with operational and environmental conditions helps in optimizing asset performance

Qualitrol's Xpert Services team of highly experienced, PD specialists can help analyse PD data from the QPDM and provide reports and recommendations. Support is also available on system installation and testing.





### Outstanding sensitivity and accuracy ensures superior analysis and rapid fault detection

The QPDM has industry leading sensitivity of -80 dBm and wide band selections, covering 300 to 2100 MHz, reducing the chance of missing Partial Discharge activity.

High dynamic range of 70 dB enables better analysis of PD activity with larger amplitude variations.

Real-time monitoring of Partial Discharge amplitude and discharge rate helps in correlating PD activity with Load, OLTC operations etc.

A trend view of PD amplitude and discharge rate provides an indication of PD Activity. Using the QPDM to monitor historical activity helps optimize asset maintenance scheduling.

### Robust design and excellent interference immunity for measurements under difficult environmental conditions

The QPDM monitor enclosure is IP66 rated. Built-in LED indicators and remote client software enable safe operation in harsh environmental conditions.

Noise gating is provided by an external signal antenna (optional).

### Confidence with Qualitrol DMS

Qualitrol DMS has over 25 years of experience in supplying UHF based PD monitoring systems to utilities across the world.

We provide long term serviceability assurance and upgrade options to the QPDM system.

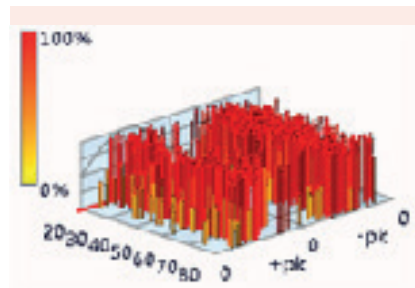

## UHF

**UHF technology is industry proven for online monitoring of Partial Discharge in the insulation of high voltage apparatus.**

UHF has excellent interference immunity and a sensitivity higher than any other kind of PD measurement e.g., DGA, acoustic or conventional measurements. Immediate detection of PD (earlier than DGA) makes it ideal for online monitoring.

---

# UHF PD SENSORS

Qualitrol's UHF sensors are the key components of any PDM system. They detect the UHF signals induced from PD pulses and transfer the signal to the data acquisition system for interpretation. The QPDM can be connected with any available UHF sensor; internal, window or drain valve. The system can be scaled from 1 to 6 sensors.



## Internal Sensors

In new transformers the sensors are usually fitted internally, inside the tank wall.



## Window Sensors

For retrofitted systems, external sensors can be fixed in transformer tap changers or available hand or manhole covers.



## Drain Valve Sensors

For retrofitted systems, external sensors can also be inserted in the transformer drain valves.



## Custom Sensors

Qualitrol can custom-design all types of UHF sensors for particular applications.

Internal sensors act as antennas picking up UHF signals emitted from PD. Complete protection for sensitive electronics of the QPDM is assured by fitting an external protector which suppresses dangerous voltages or transients.

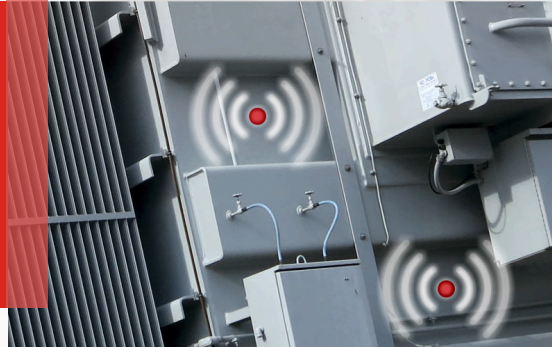

Replacement hatch covers are prepared before the installation. Sensors are fitted on top of tank to the replacement hand or manhole covers. Oil is only drained to a few cm below the hatch level and outage times are kept to a minimum.

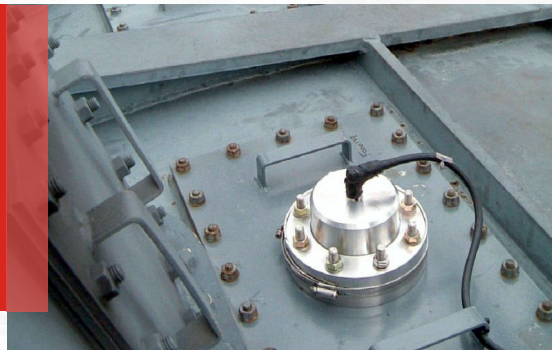

Qualitrol's drain valve sensor can be easily and rapidly retrofitted to the existing transformer oil drain / filter valve.

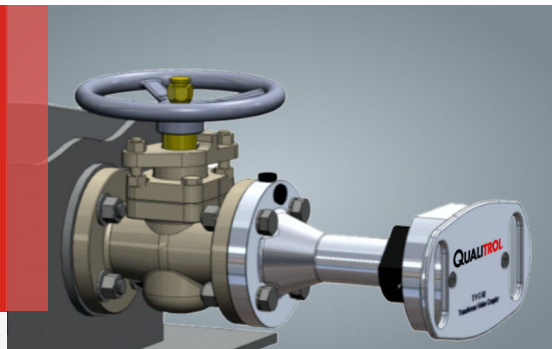

Qualitrol can calibrate all custom designed sensors to ensure they meet any customer specifications for sensitivity and bandwidth.

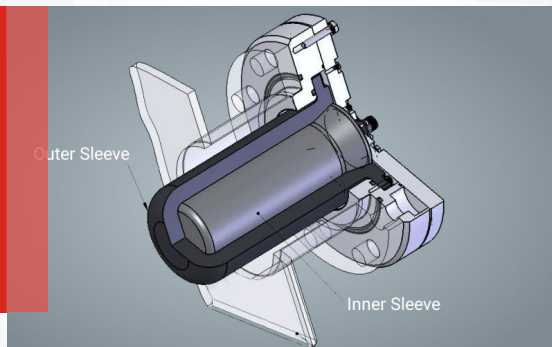

# REMOTE CLIENT SOFTWARE

Qualitrol's advanced remote client software is used for configuration (system and alarm settings), data visualization, PD analysis and reporting. Instant visualization of PD characteristics enables faster and smarter responses to real-time operational challenges.

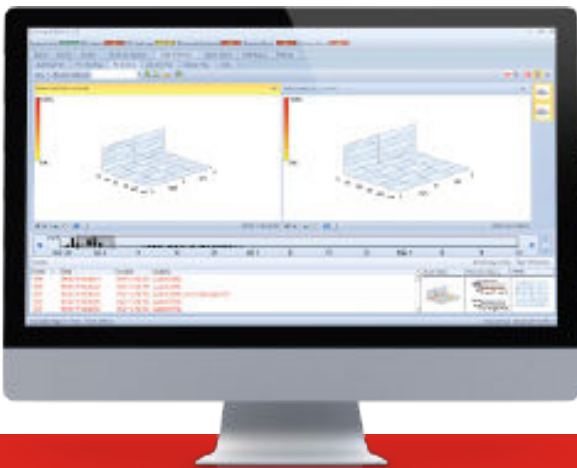

## Key Features:

- 2D, 3D, point-on-wave PRPD and PRPS data display and analysis; PRPD, STT real-time displays (optional)
- Data stored on solid state drive for up to 5 years
- Data library of typical defects
- Automatic self-check of PDM with logging and alarming
- Configurable alarm criteria
- Alarm notification and data output using IEC 61850 or Modbus



The data can be viewed in a number of ways including point-on-wave (2D) or in single-cycle (3D) formats.

In addition, trend analysis identifies irregular changes in the parameter levels defining the PD activity and alerts the operator.

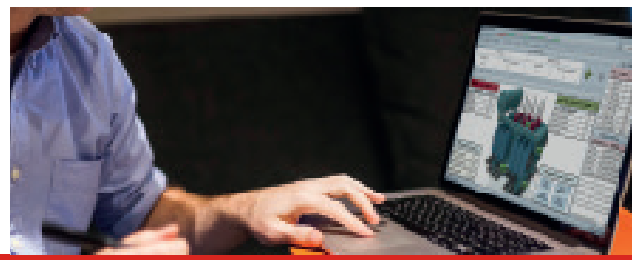

# Technical Overview

## QPDM Unit

|               |   |
|---------------|---|
| Voltage range | 90 to 264 V AC; 50/60 Hz  |
| Output        | 4 x SCADA/SCS alarms contacts for PD Warning, PD Alarm and System Fault<br>4 x LED status indicators (bi-color) |

## Inputs and Outputs

|                     |  |
|---------------------|--|
| Input (UHF)         | Supports 1 to 6 channels for UHF sensor inputs   |
| Input (noise)       | 1 separate noise channel for external noise antenna  |
| Frequency bandwidth | 300 MHz to 2100 MHz with HDR card<br>4 selectable bands: 440 - 800 MHz, 300 - 800 MHz, 1100 - 2100 MHz,<br>300 - 1200MHz (default) |
| Dynamic range       | 70 dB  |
| Sensitivity         | -80 dBm  |
| Sample rate         | 15360 samples/s per channel at 60 Hz   |
| Output              | Ethernet (multi/single mode fiber optic or RJ45)   |
| Output protocols    | IEC61850 / Modbus  |

## Environmental

|                               |   |
|-------------------------------|---|
| Ambient operating temperature | -55° to +55° C [-13° to +131° F]. (Custom ranges available) |
| Storage temperature           | -55° to +85° C [-13° to +185° F]                            |
| Humidity                      | 5 to 95%, non-condensing                                    |
| Enclosure rating              | IP66  |
| Seismic                       | IEEE C37.98 (seismic testing of relays)                     |
| Environmental test compliance | BS EN60068-2-2, BS EN60068-2-1, BS EN60068-2-78             |
| Vibration test compliance     | BS EN68-2-6, BS EN68-2-27, BS EN68-2-29                     |

## Immunity and Mechanical

|                     |  |
|---------------------|--|
| EMC test compliance | Conforms to relevant specifications for monitoring / control equipment in HV substations. BS EN55022 (:2006); BS EN61000-3-2 to -3-3, BS-EN61000-4-2 to -4-6, BS EN61000-4-8, BS EN61000-4-11, BS EN61000-4-18; IEC 60255-5, IEC 61180-1 |
| Others              | CE and RoHS Compliance   |
| Dimensions          | 600 mm (height) x 430 (width) x 210 mm (depth). [23.6" x 16.9" x 8.3"]   |
| Weight              | 25 kg [55.2 lbs]   |



Contact Us

---

## Qualitrol<sup>®</sup> DMS

74 Black Street, Glasgow, G4 0EF  
United Kingdom

Ph. +44.141.572.0840  
e.info@qualitrolcorp.com

Visit our website for more information  
and a complete portfolio

**[www.qualitrolcorp.com](http://www.qualitrolcorp.com)**