

TECHNICAL GUIDE

Combined Resin Silicon Bushings

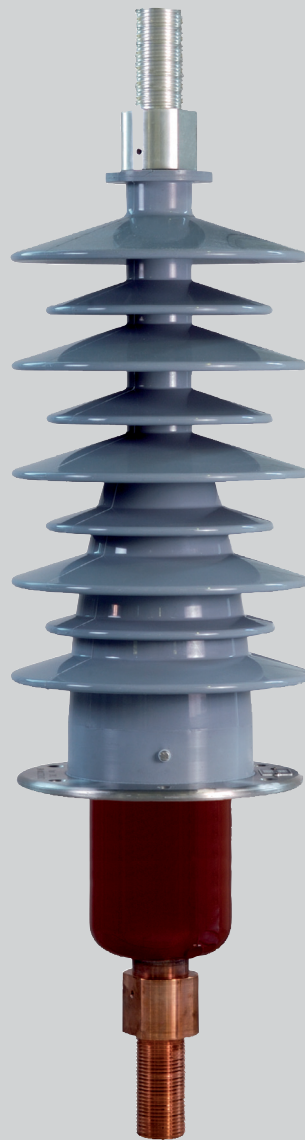

Content index

Technical data	4
Dimensions.....	5
Order sheet.....	10

Technical data

CRS (IEC 60137 – IEC60815/3(sheds shape))

Voltage kV	Rated Current A	BIL kV	Dry Power Frequency kV	PD 1.5Um/ √3 pC	Creepage distance mm	Arcing distance mm	Operating load N	Pollution Level	Oil temperature range °C
24	250	150	55	10	710	290	500	P2	-20°C/100°C
36	250	200	77	10	1320	485	500	P4	
24	630	150	55	10	710	305	500	P2	
36	630	200	77	10	1320	500	500	P4	
24	1250	150	55	10	1360	515	625		-40°C/120°C (NBR); upon request available -60°C (FVMQ)
36	1250	200	77	10	1360	515	1000		
24	2000	150	55	10	1500	515	1000		
24	3150	150	55	10	1500	515	1575		
36	2000	200	77	10	1500	515	1000		
36	3150	200	77	10	1500	515	1575		
24	5000	150	55	10	1300	490	1575	P4	
24	6300	150	55	10	1300	490	1575		
36	5000	200	77	40	1300	490	1575		
36	6300	200	77	40	1300	490	1575		
52	1250	250	105	40	1630	563	625		
52	2000	250	105	40	1630	563	1000		
52	3150	250	105	40	1630	563	1575		
72.5	1250	325	155	90	2250	775	625		
72.5	2000	325	155	90	2250	775	1000		

CRS IEEE (IEEE C57.19.01-2000 - IEEE C57.19.00-2004)

Voltage kV	Rated Current A	Line to ground Voltage kV	BIL kV	Dry Power Frequency kV	PD 1.5Um/ √3 pC	Rated Voltage kV	Rated Current A	Creepage distance mm/inc	Arcing distance mm/inc	Operating load N/lbf	Oil temp. range °C	Tanδ @20kV
25	3000	16	150	75	25	25	3000	1220/ 48.03	450/ 17.7	1300/ 300	-60/120	0.004
34.5	3000	22	200	100		34.5	3000					

Coating

Coating	Material
Active part in air (for rated current < 630A)	Nickel
Active part in air (for rated current > 630A-3150A for IEC only)	Tinned
Active part in air (for IEC rated current > 3150A and for all types IEEE)	Silver
Active part immersed in oil (for all bushing types)	no coating

Gasket

Gasket	Material
For rated current ≥ 1250A	NBR
For rated current from 250A to 630A	Cork

Dimensions

CRS (IEC)

CRS (24-36KV/250-630A)

Type	A mm	B mm	C mm	C1 mm	D	D1 mm	D2 mm	D3 mm	F mm	G mm	H mm	Number of sheds	Weight Kg
24kV/250A P2	492	137	60	40	M12	Ø160	Ø148	Ø60	295	-	97	5	3.6
36kV/250A P4	709	137	60	40	M12	Ø160	Ø148	Ø60	512	-	97	9	5.5
24kV/630A P2	517	147	75	50	M20	Ø160	Ø164	Ø60	295	-	97	5	4.6
36kV/630A P4	734	147	75	50	M20	Ø160	Ø164	Ø60	512	-	97	9	6.5

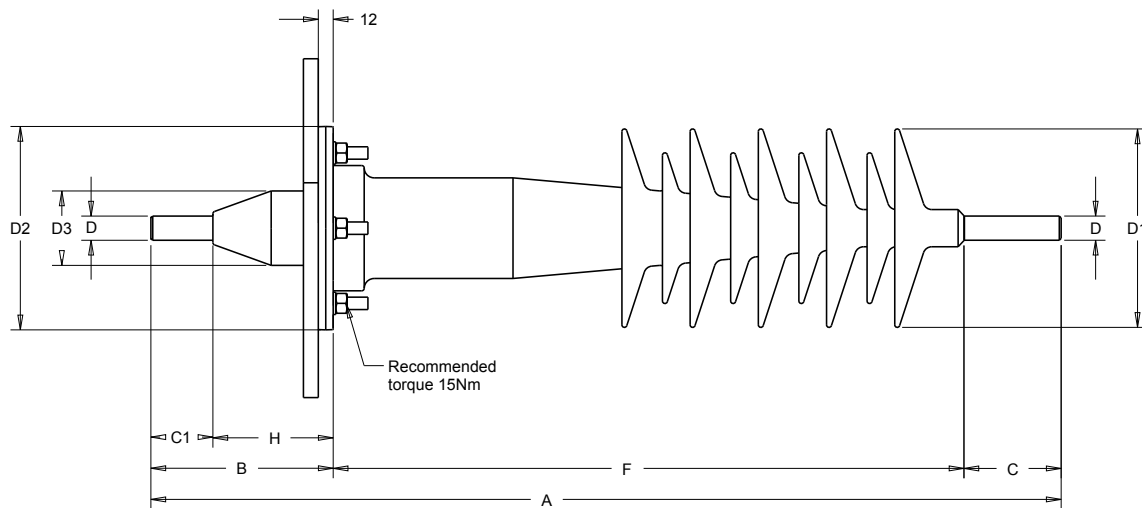

Dimensions

CRS (IEC)

CRS (24-72.5KV/1250-6300A)

Type	A mm	B mm	C mm	D mm	D1 mm	D2 mm	D3 mm	F mm	G mm	H mm	Number of sheds	Weight Kg
24-36kV/1250A	820	235	65	M30x2	Ø222	Ø225	Ø92	470	115	110	9	21.7
24-36kV/2000A	865	260	85	M42x3	Ø254	Ø240	Ø110	470	135	110	9	25.4
24-36kV/3150A	865	260	85	M48x3	Ø254	Ø240	Ø110	470	135	110	9	26.2
52kV/1250A	893	280	65	M30x2					115			30
52kV/2000A	933	300	85	M42x3	Ø250	Ø240	Ø120	498		150	9	33
52kV/3150A			85	M48x3					135			35
72.5kV/1250A	1123	325	65	M30x2					115			43.5
72.5kV/2000A	1163	345	85	M42x3	Ø300	Ø290	Ø130	683		195	12	46.5
24-36kV/5000-6300A	846	206	102	Ø78	Ø280	Ø320	Ø154	498	142	150	8	60

1250 - 2000 - 3150A

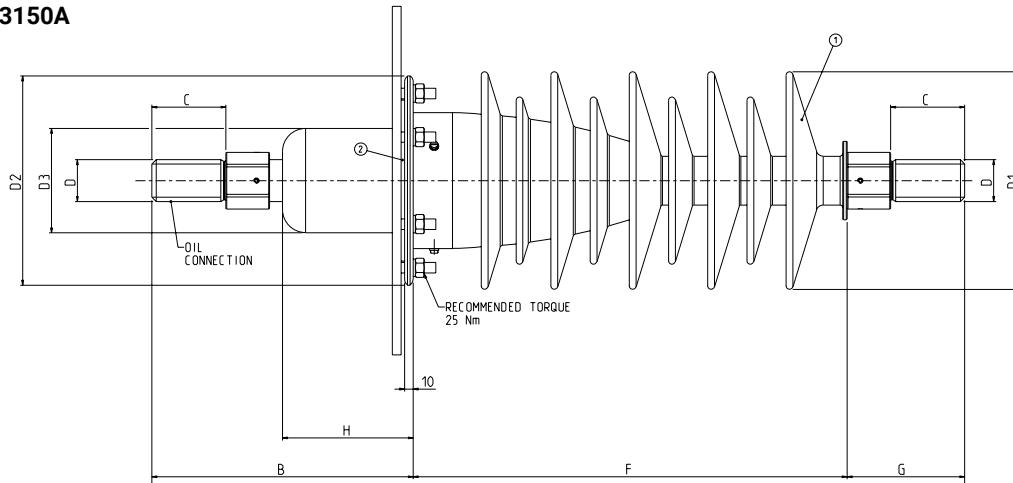

5000 - 6300A

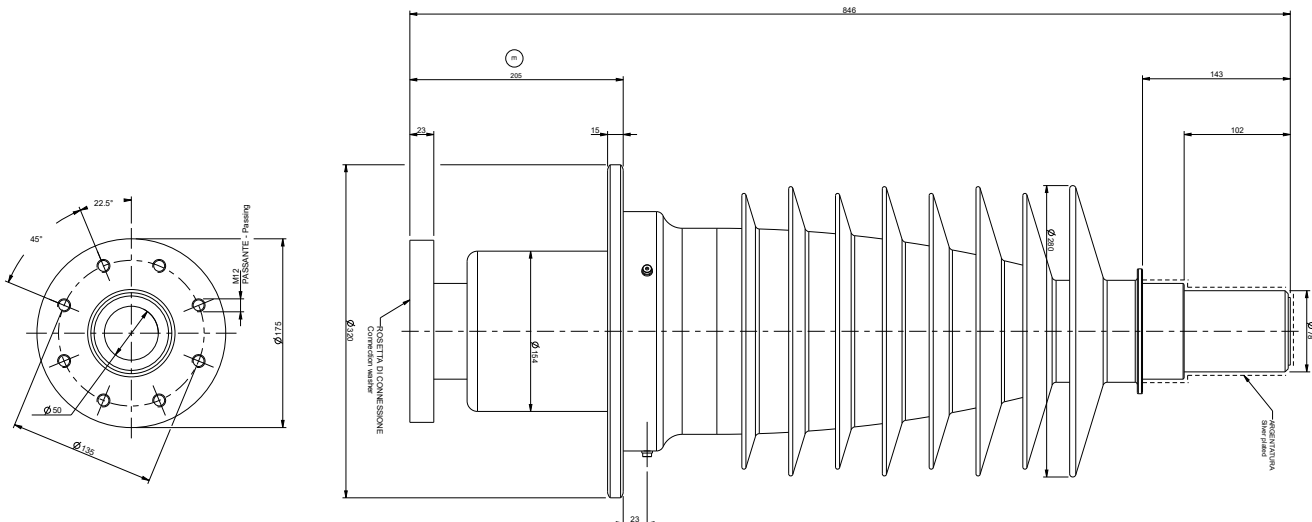

COMEM is an ISO 9001 system certified. Information subject to change without notice

Dimensions

CRS (IEEE)

Type	A mm/in	B mm/in	L mm/in	R	P mm/in	Q mm/in	W ⁽²⁾ mm/in	D mm/in	MTG ⁽¹⁾ mm/in	Number of sheds	Weight Kg/lb
25-34.5kV 3000A	86.5 3.406"	626 24.65"	857 33.74"	3"-12UN-2A	159 6.25"	213 8.39"	535 21"	120 4.725"	30 1.18"	7	65 143.3

(1) MTG: minimum oil level dimension over the current transformer radius

(2) W: current transformer pocket length and distance from flange mounting surface to minimum oil level

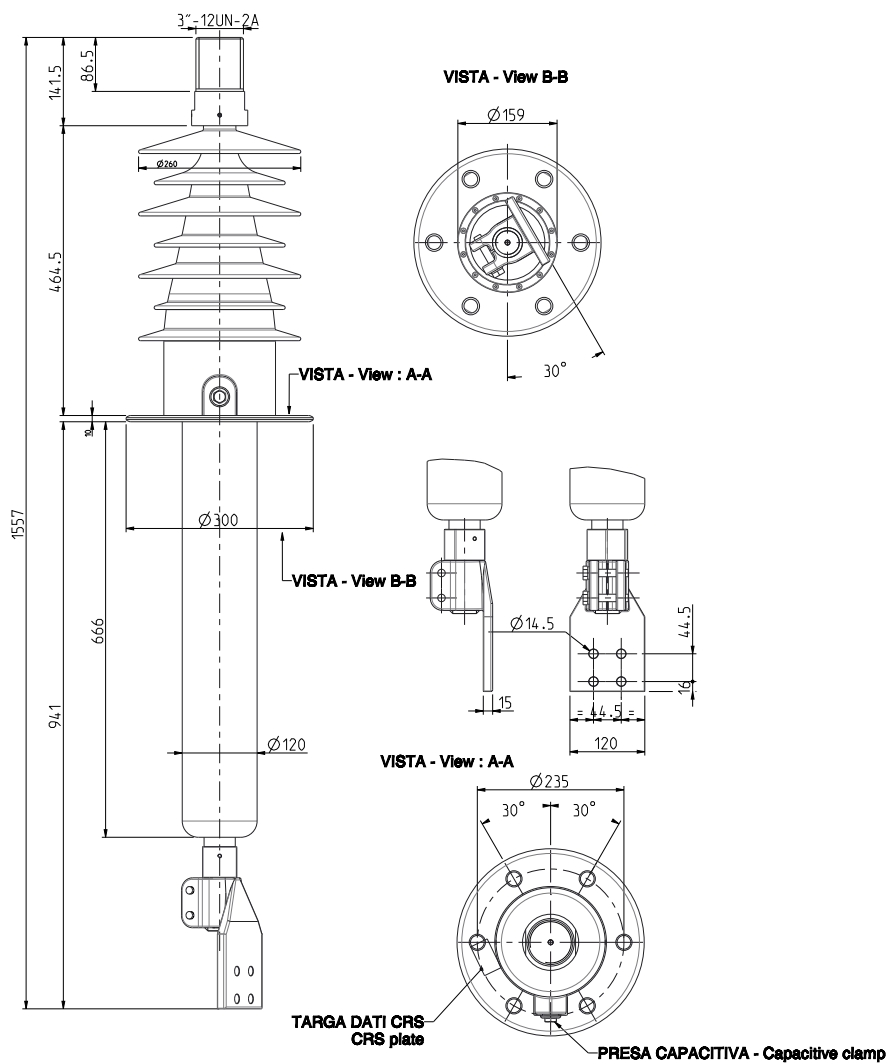

Dimensions

Fixing flange

CRS (24-72.5kV/1250-6300A)

Type	D tank hole mm	D1 mm	D2 mm	D3 mm	M	No. Of bolts
24-36kV / 1250A	Ø102	Ø180-Ø185	-	-	M12	6
24-36kV / 2000-3150A	Ø115	Ø200-Ø205	-	-	M12	6
24-36kV / 5000-6300A	Ø180	-	-	Ø280	M12	10
52kV / 1250-3150A	Ø130	Ø200-Ø205	-	-	M12	6
72.5kV / 1250-2000A	Ø140	-	Ø250	-	M14	8

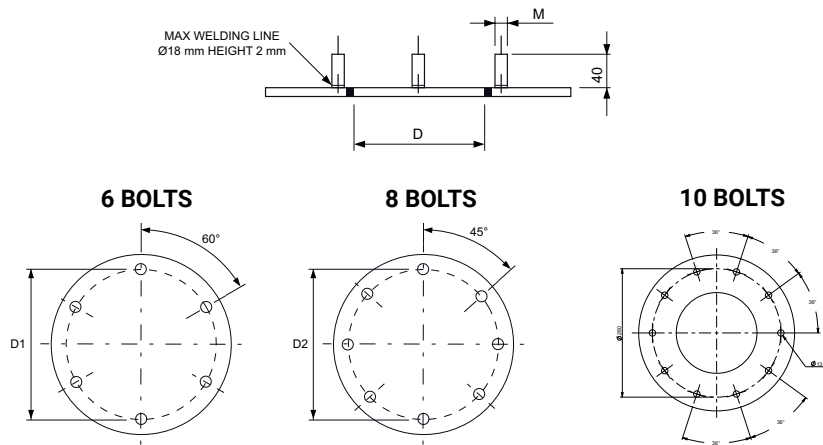

CRS (24-36kV/250-630A)

Type	D tank hole mm	D1 mm	D0 mm	M	No. of bolts
24-36kV / 250A	Ø80	-	Ø123	M10	4
24-36kV / 630A	Ø90	Ø140	-	M10	6

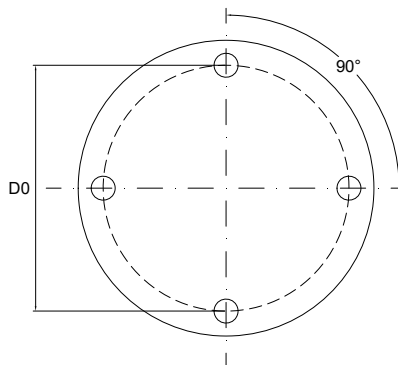

CRS (IEEE)

Type	D4 tank hole mm/in	ØD5 mm/in	Q	No. Of bolts
25-34.5kV/3000A	130/5.118"	235/9.252"	M20	6

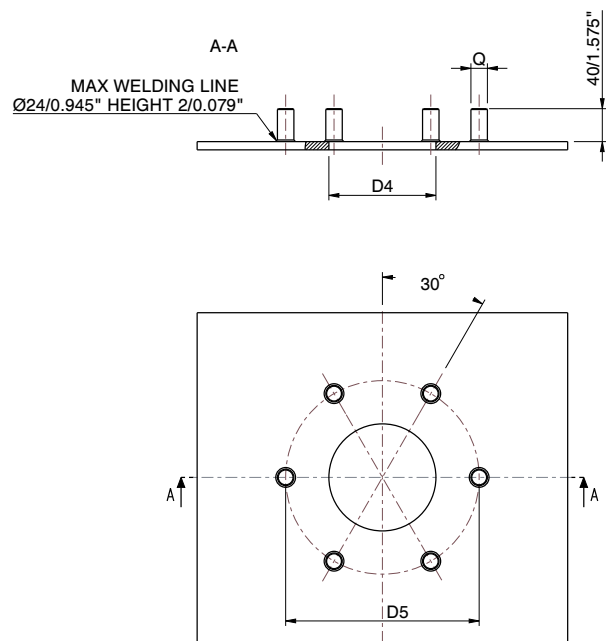

Order sheet

Type

	IEC 60137 – IEC60815/3(sheds shape)
	IEEE C57.19.01-2000 - IEEE C57.19.00-2004

Date	
Rev.	
Customer reference	

Rated Voltage (kV)

	24	IEC
	25	IEEE
	34.5	IEEE
	36	IEC
	52	IEC
	72.5	IEC

Rated current (A)

	250	IEC
	630	IEC
	1250	IEC
	2000	IEC
	3000	IEEE
	3150	IEC
	5000	IEC (only 24-36kV)
	6300	IEC (only 24-36kV)

Gasket (for rating >1250A)

	NBR (standard)
	FVMQ (Fluorosilicon) - Arctic version (-60°C)

Accessories for lower part

Notes

	Flag ⁽¹⁾	
	Customer drawing	

(1) Not applicable on CRS with nominal current 5000A and 6300A

Accessories for upper part

Notes

	Flag ⁽²⁾	
	Customer drawing	

(2) Available only tinned or silver plated in agreement with the features of CRS

COMEM SpA

Localita' Signolo 22, S.R.11
36054 Montebello Vicentino
Vicenza - Italy
Tel +39 0444 449 311

www.comem.com

The data and illustrations are not binding. We reserve the right to modify the contents of this document without prior notice following the technical and product developments.

Copyright 2025 COMEM. All rights reserved

Technical guide-01-2025