

BROCHURE

PPS-PPQ-BT

Resin insulators for oil insulated electrical machines



Bushing with plug connection with outer cone PPS



Characteristics

The PPS® bushing can be used as a fixed section for the entry of medium voltage on oil filled machines such as switch gears or transformers. It is fitted with a coupling interface according to table 1.

Application

Indoors for vertical or horizontal mounting

Accessories (on request)

Fastening kits for insulators with DIN flanges or with French blocks, and earthing wires can be ordered.

Identification		Standards			Oil level		Version with flange	Dry power frequency	Lighting impulse
Type	Catalog nr:	Interface	Interface IPE	Complete insulator	Dimension "X"		Type	kV	kV
24 kV / 250 A	PPS 24/250	EN 50180 / UTE C 66-555 IEEE Std 386	A	EN 50180 / DIN 47636 HN 52-S-61	6 - 10 kV 40 mm 12 - 20 kV 50 mm		"A" DIN 42538	55	125
24 kV / 250 A (Short)	PPS 24/250-R	EN 50180 / EN 50181 HN 52-S-61 IEEE Std 386	A	UTE C 66-555	Total		"A" DIN 42538	55	125
24 kV / 250 A (Short)	PPS 24/250-R with threaded inserts	EN 50180 / EN 50181 HN 52-S-61 IEEE Std 386 UTE C 66-555	A	COMEM	Total		"A" DIN 42538	55	125
24 kV / 250 A (Long)	PPS 24/250-L	EN 50180 / EN 50181 HN 52-S-61 IEEE Std 386	A	COMEM	6 - 10 kV 40 mm 12 - 20 kV 50 mm		"A" DIN 42538	55	125
24 kV / 1250 A	PPS 24/1250	EN 50180 / EN 50181	D	COMEM	Total		DIN 42542	77	170
36 kV / 250 A	PPS 36/250	EN 50180 / HN 52-S-61 EN 50181	B	UTE C 66-555	Total		*	77	170
36 kV / 400 A	PPS 36/400	EN 50180 EN 50181 / HN 52-S-61	B	EN 50180 / DIN 47636	6 - 10 kV 40 mm 12 - 20 kV 50 mm 18 - 30 kV 70 mm		"B" DIN 42538	77	170
36 kV / 630 A	PPS 36/630	EN 50180 / EN 50181	C	EN 50180	6 - 10 kV 40 mm 12 - 20 kV 50 mm 18 - 30 kV 70 mm		"B" DIN 42538	77	170
42 kV / 630 A	PPS 42/630	EN 50180 / EN 50181	C	EN 50180	6 - 10 kV 40 mm 12 - 20 kV 50 mm 18 - 30 kV 70 mm		"B" DIN 42538	85 95 (High TG)	200

Dimensions - PPS type

PPS 24 kV / 250 A

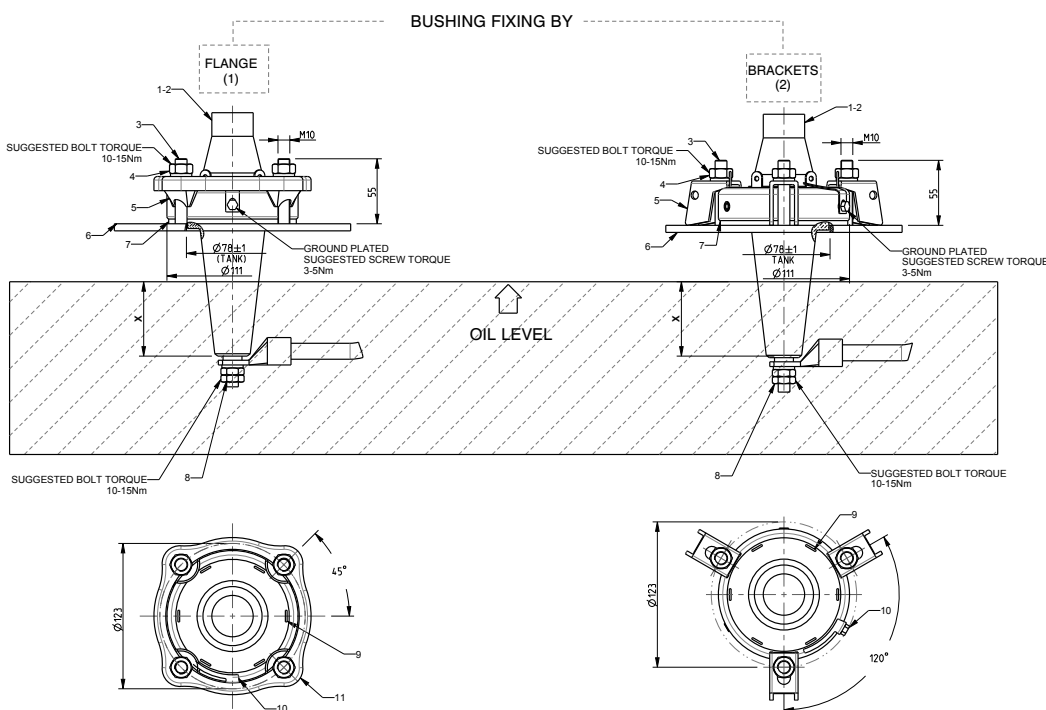

1

Pos	Description
1	Protective cover
2	Connection interface
3	Studs
4	Fixing bolts
5	Blocks
6	Tank cover
7	Gasket
8	Connection bolt
9	Fixing shoe
10	Ground plated
11	Fixing flange

2

Pos	Description
1	Protective cover
2	Connection interface
3	Studs
4	Fixing bolts
5	Brackets
6	Tank cover
7	Gasket
8	Connection bolt
9	Fixing shoe
10	Ground plated

PPS 24 - 36 KV / 400 - 630 A

1

Pos	Description
1	Protective cover
2	Connection interface
3	Studs
4	Fixing bolts
5	Blocks
6	Tank cover
7	Gasket
8	Connection bolt
9	Fixing shoe (only 400A)
10	Ground plated
11	Fixing flange

2

Pos	Description
1	Protective cover
2	Connection interface
3	Studs
4	Fixing bolts
5	Brakets
6	Tank cover
7	Gasket
8	Connection bolt
9	Fixing shoe (only 400A)
10	Ground plated

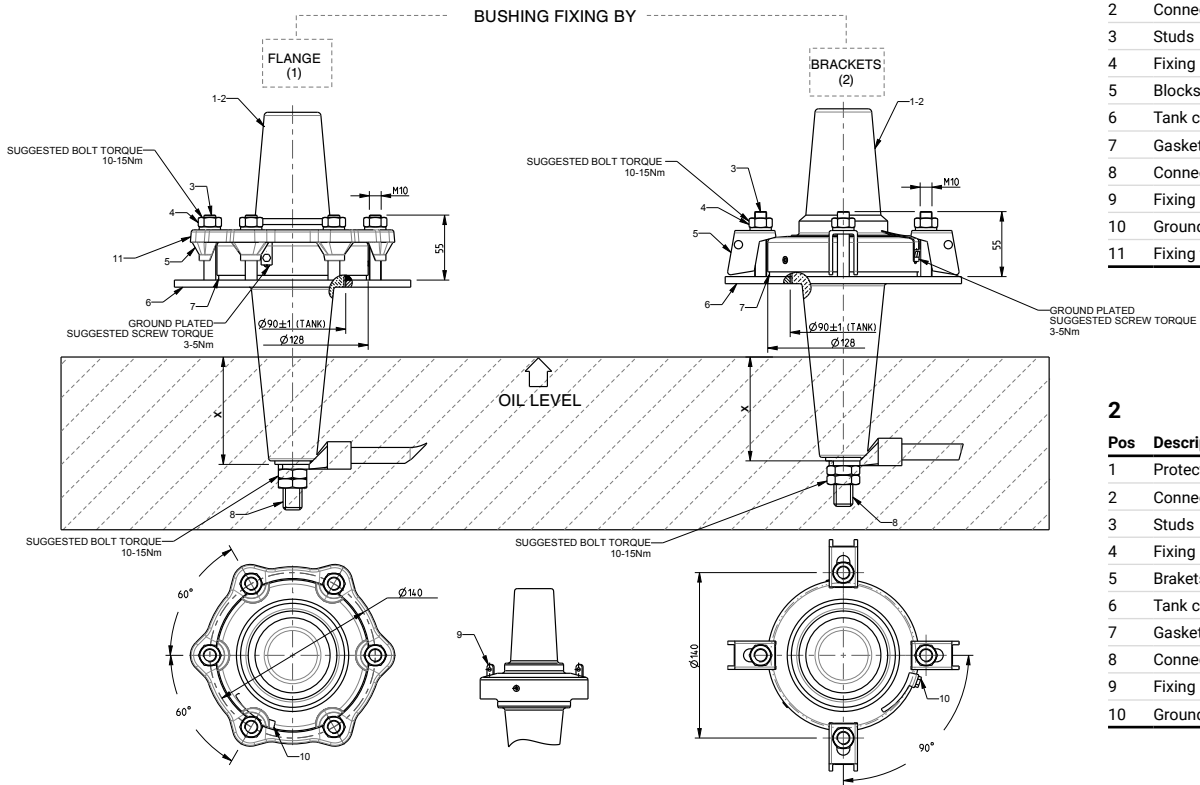

Titolo: PPS 36 kV / 250 A

Pos	Description
1	Protective cover
2	Connection interface
3	Studs
4	Fixing bolts
5	Brakets
6	Tank cover
7	Gasket
8	Connection bolt
9	Fixing shoe
10	Ground plated

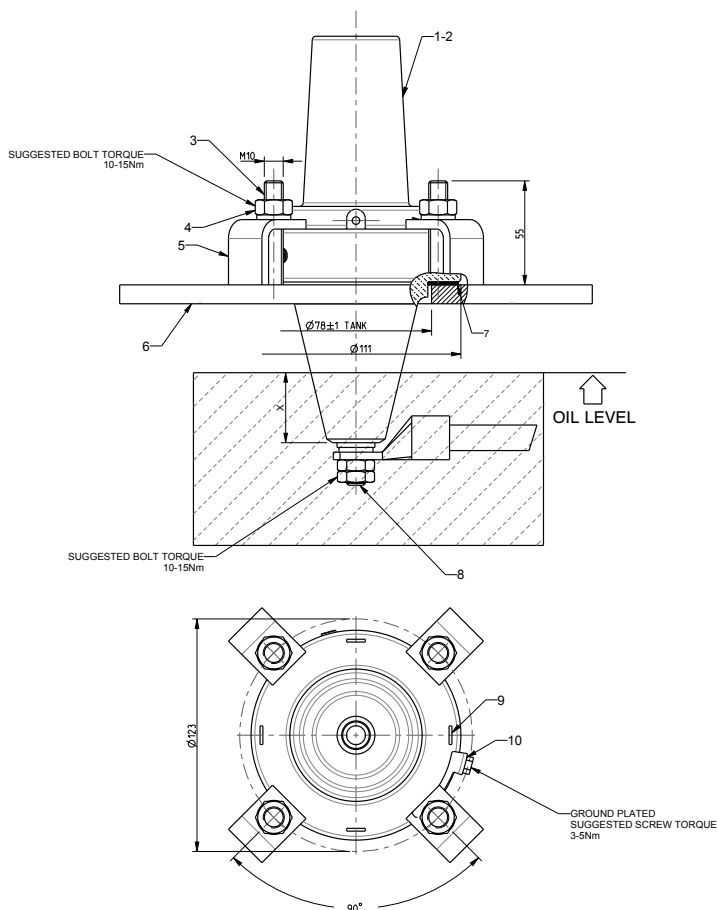

PPS 24 kV / 1250 A

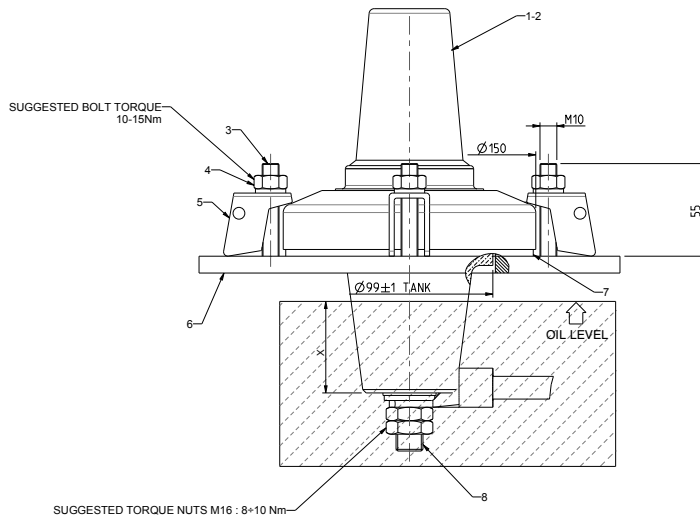

Pos	Description
1	Protective cover
2	Connection interface
3	Studs
4	Fixing bolts
5	Brackets
6	Tank cover
7	Gasket
8	Connection bolt
9	Ground plated

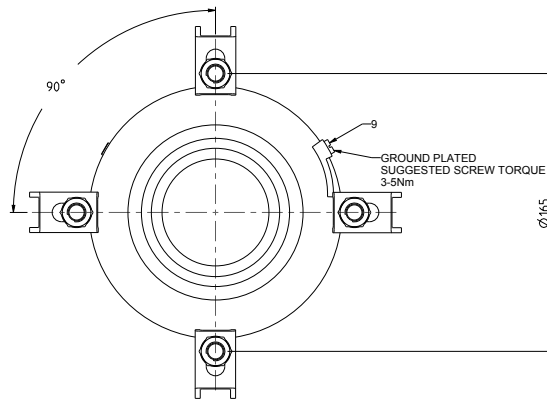

Important recommendations

- Do not coat or pollute the connection interface in any way whatsoever.
- When the bushing is not connected to other equipment through the rubber terminal, the plastic protective cover must always be set firmly in place.
- Carefully clean the protective cover before replacing it on the bushing after having removed the mobile terminal.
- Remove the protective cover before actuating the bushing.
- At least one of the three lateral plugs of the screen must be earthed as shown in figures 1 and 2.

Bushing with plug connection with inner cone PPQ



Characteristics

The PPQ bushing can be used as fixed part in the medium voltage input in electrical oil insulated machines, such as transformers or switchgears. It is equipped with a coupling interface according to the - DIN 47637 - standards.

Application

For indoor application, vertical and horizontal mounting.
For outdoor applications, energized or not energized through its rubber connector, vertical and horizontal mounting.

Cast resin bushing BT



BT 1/1250

According to table ENEL DJ 1107 - DJ 1109

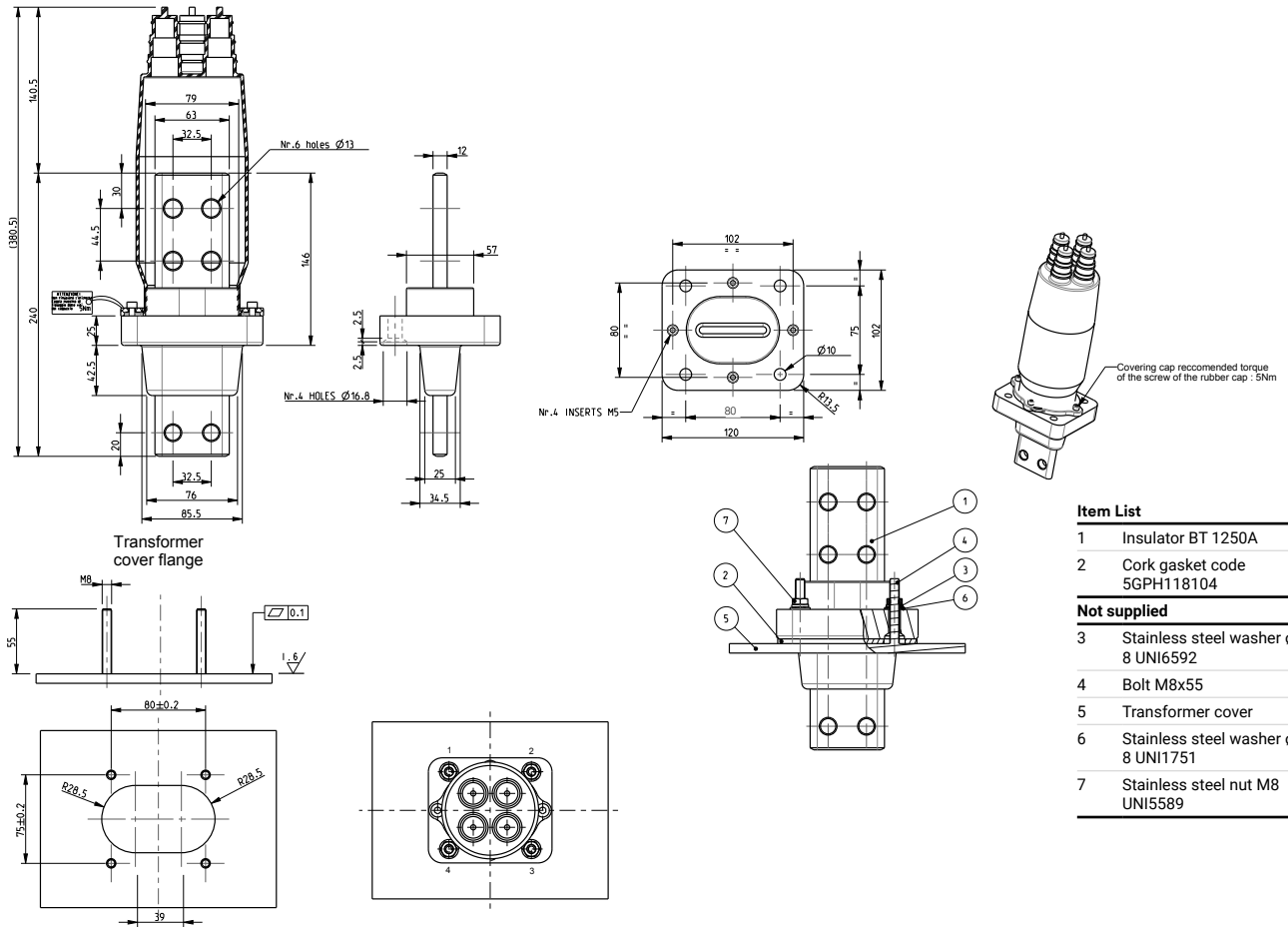

Item List

1	Insulator BT 1250A
2	Cork gasket code 5GPH118104

Not supplied

3	Stainless steel washer ϕ 8 UNI6592
4	Bolt M8x55
5	Transformer cover
6	Stainless steel washer ϕ 8 UNI1751
7	Stainless steel nut M8 UNI5589

Assembling instructions

- Screw the 4xM8 nuts according to a cross sequence 1-3-4-2
- 1st step : 2 Nm
- 2nd step : 5 Nm
- 3rd step : 12 Nm (max)

BT Busbar bushings



The single phase busbar bushings according to EN 50387 Standard are suitable for indoor oil-air applications on liquid filled transformers.

The bushing is composed by a galvanic coated bar moulded inside an insulated resin flange.

Our technical solution does not require any gasket sealing system. It also grants a significant costs saving of transformer maintenance.

Special length of busbars, drilling terminations and accessories are also available on request.

BT 1600A

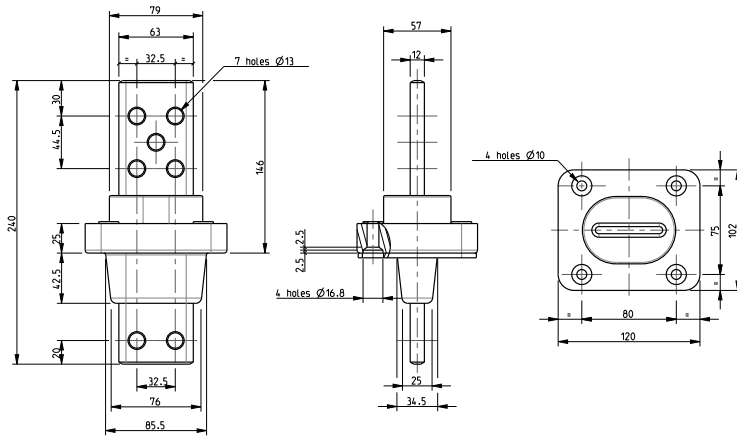

Transformer cover flange

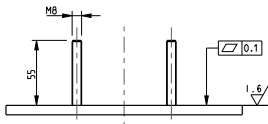

Assembling instructions:
 Screw the 4xM8 nuts according to a cross sequence 1-3-4-2
 1st step : 2 Nm
 2nd step : 5 Nm
 3rd step : 12 Nm (max)

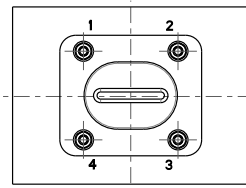
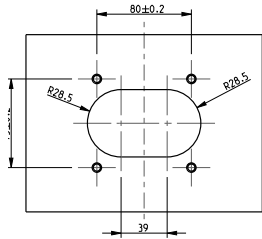

Technical features:

Standard	EN50387
Nominal current:	1600 A
Nominal voltage	1 kV
Dry power frequency	10 kV
Dry lighting impulse withstand voltage	20 kV
Min creepage distance	55 mm
Max operating cantilever load	625 N
Thermal short time current withstand test	16,5 kA
Dynamic short circuit current with-stand test	41 kA
Operating temperature	-20°C÷100°C

BT 1600 - GST001

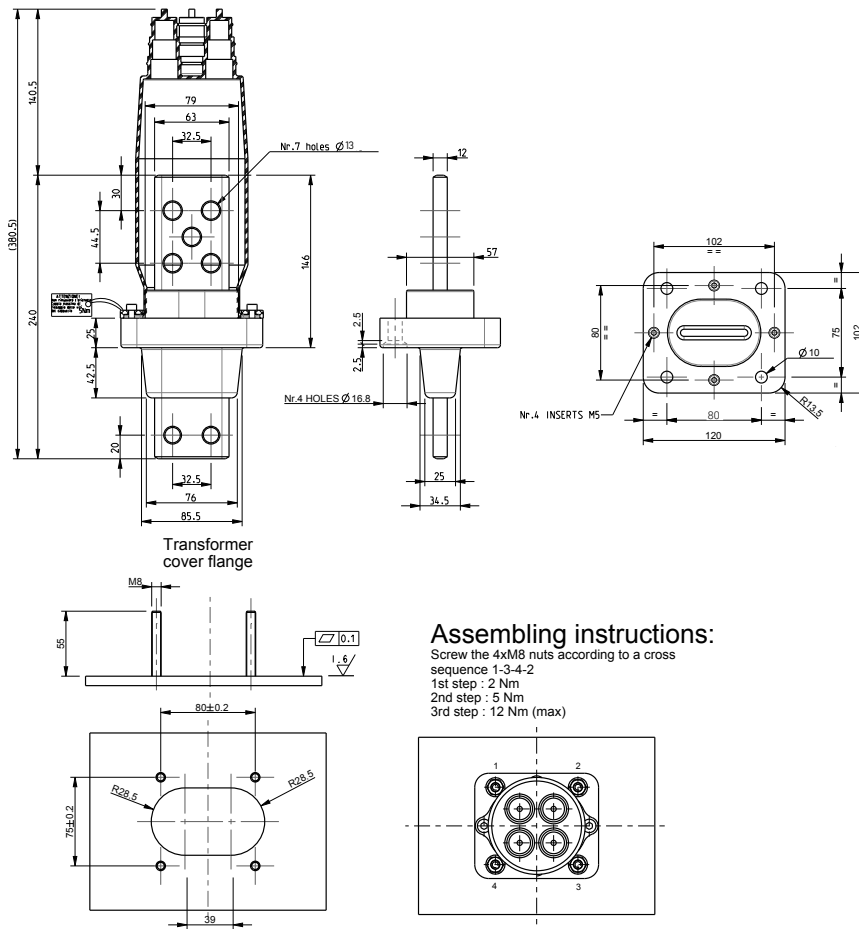

Technical features:

Standard	GST001
Nominal current:	1600 A
Nominal voltage	1 kV
Dry power frequency	10 kV
Dry lighting impulse withstand voltage	20 kV
Min creepage distance	55 mm
Max operating cantilever load	625 N
Thermal short time current withstand test	16,5 kA
Dynamic short circuit current with-stand test	41 kA
Operating temperature	-20°C÷100°C

BT 2000A

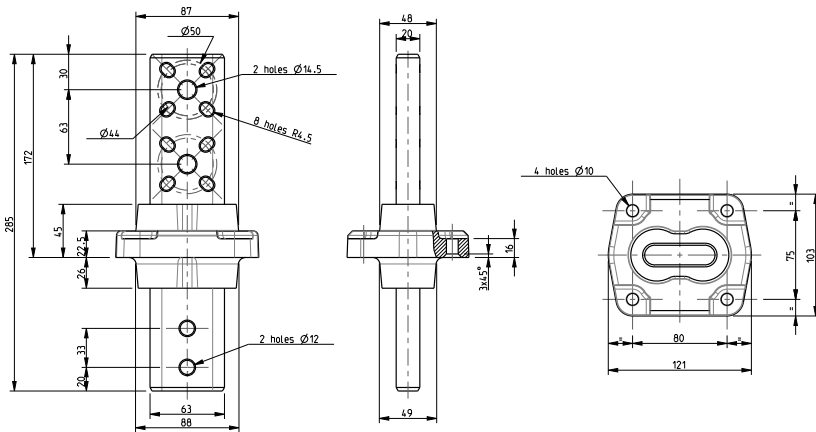

Transformer cover flange

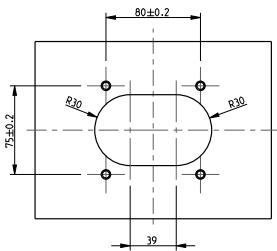
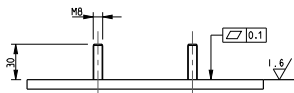

Assembling instructions:

Screw the 4xM8 nuts according to a cross sequence 1-3-4-2
 1st step : 2 Nm
 2nd step : 5 Nm
 3rd step : 12 Nm (max)

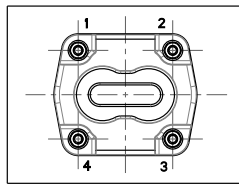

Technical features:

Standard	EN50387
Nominal current:	2000 A
Nominal voltage	1 kV
Dry power frequency	10 kV
Dry lighting impulse withstand voltage	20 kV
Min creepage distance	55 mm
Max operating cantilever load	1000 N
Thermal short time current withstand test	29 kA
Dynamic short circuit current with-stand test	72.5 kA
Operating temperature	-20°C÷100°C

BT 2500

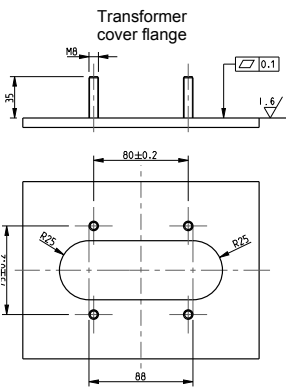
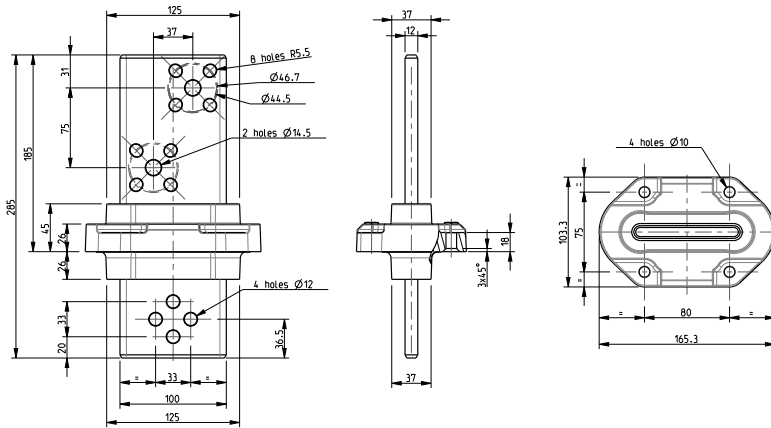

Assembling instructions:
 Screw the 4xM8 nuts according to a cross sequence 1-3-4-2
 1st step : 2 Nm
 2nd step : 5 Nm
 3rd step : 12 Nm (max)

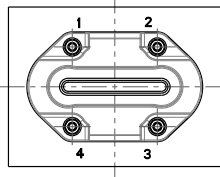

Technical features:

Standard	EN50387
Nominal current:	2500 A
Nominal voltage	1 kV
Dry power frequency	10 kV
Dry lighting impulse withstand voltage	20 kV
Min creepage distance	55 mm
Max operating cantilever load	1000 N
Thermal short time current withstand test	36 kA
Dynamic short circuit current with-stand test	90 kA
Operating temperature	-20°C÷100°C

BT HC (High Current)

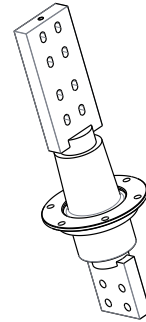
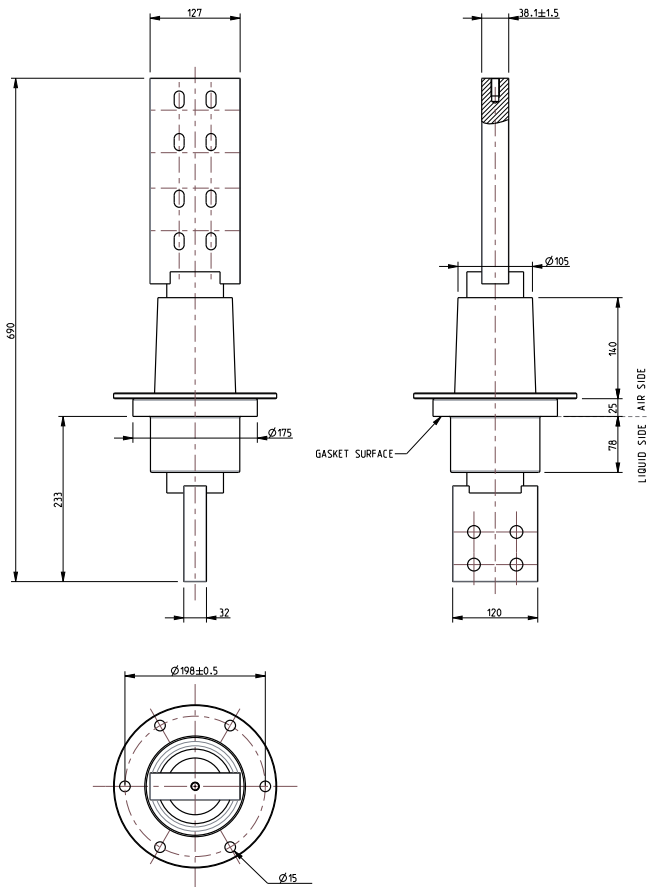

Technical features:

Nominal current:	from 4000 up to 8000 A
Nominal voltage	from 1 up to 3 kV
Customized solution	
Epoxy resin insulator for indoor application	
Test according to IEC 60137	

www.comem.com

The data and illustrations are not binding. We reserve the right to modify the contents of this document without prior notice following the technical and product developments.

Copyright 2025 COMEM. All rights reserved

Brochure-English-08-2025

COMEM SpA

Localita' Signolo 22, S.R. 11
36054 Montebello Vicentino
Vicenza - Italy
Tel +39 0444 449 311