

AKM OLR

Remote mechanical oil level indicators



See oil level with ease at eye level

- Automate transformer protection with electronic alarm and control functions
- Made to customer specifications with a wide variety of options
- Robust materials and design provide long, trouble free life
- All electrical wiring is made inside the instrument

Product Summary

Description Hydro-mechanical, capillary based, oil level indicator (liquid level gauge). Provides accurate indication of level at the safest and most convenient location, eye level. Designed for use in even the highest conservator tanks. Includes integrated microswitches for control and alarm functions. Electronic output for SCADA integration is available.

Application For oil level indication with integrated control and alarm functions. Designed for use where the point of measurement is not easily viewed by personnel requiring separate or remote indication.



QUALITROL®
Defining Reliability

AKM OLR remote mechanical oil level indicators

See oil level with ease at eye level

- The flexible capillary tubing allows the indicator to be placed in a safe and convenient location away from the actual measurement point
- Automatically compensates for the hydro-mechanical force change associated with the height difference of the measurement point and indicator
- Optional electronic transmitter allows for remote indication for distances greater than 52ft (16m)

Automate transformer protection with electronic alarm and control functions

- Standard models are equipped with 2 fully adjustable magnetic blow-out switches for alarms and/or control of auxiliary equipment
- Up to 4 switches can be integrated into the device for greater flexibility of design
- 4-20mA electronic output is available for remote indication and SCADA integration

Made to customer specifications with a wide variety of options

- Up to 52ft (16m) of capillary can be specified as needed to mount the indicator where most convenient
- Multiple tank connection (mounting flange) types are available for mounting on the side, top or bottom of the vessel
- Float arm length is specified by customer to achieve necessary geometry for measurement
- Dial scale can be customer specified

Robust materials and design provide long, trouble free life

- Die-cast aluminum casing is coated with thermosetting powder coat finish
- UV stabilized polycarbonate lens resists yellowing with age
- Stainless steel protective tubing adds extra protection for capillary
- Case is ventilated and weather-proof according to DIN 40050 protection class IP 54

All electrical wiring is made inside the instrument

- Electrical connections are well protected inside the OLR's rugged casing
- With the contacts located in the remote indicator there is no need to run electrical wires all the way to the conservator

Options and accessories

Electronic output user upgrade kit



- Add electronic output capability to units previously purchased without output
- Upgrade possible through back access panel
- Boards capable of mA, Pt100, Cu10 voltage outputs for remote indication and integration with SCADA systems



Mounting options

- Float arm and tank connection assembly can be mounted on the top, side or bottom of the vessel
- Note: 46701-0 is recommended only for bottom mounting, all other tank connections (flanges) are suitable for all mounting orientations

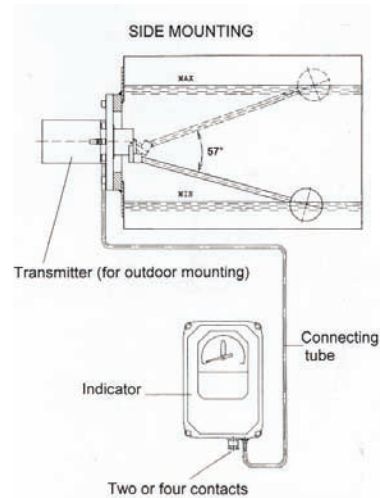
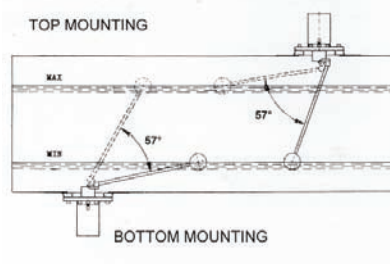

Float configurations

Float No.	A (mm)	B (mm)	L (mm)
48200-L	13	55	500 - 2000
48200-1-L	53	95	500 - 2000

The float arm should be decided so that the maximum change in oil level will correspond to 57° movement of the float arm. (see installation suggestions above)
Recommended arm length is 500-2000 mm.

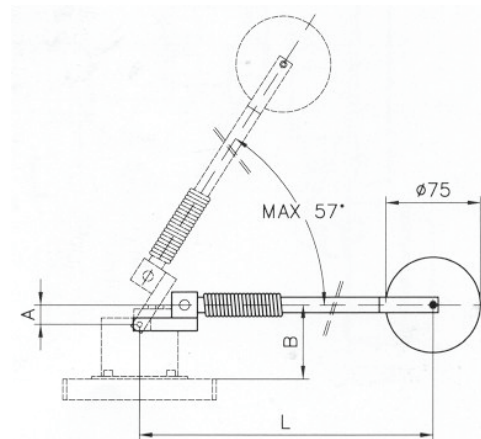

TECHNICAL SPECIFICATIONS

Mechanical	Mounting	Top, side or bottom flange mounting (square or circular)
Materials	Case	Die-cast aluminum, meets IP54
	Lens	UV stabilized polycarbonate
	Tank connection (flange)	Anodized aluminum
Environmental	Ambient operating temperature	-58 to +158°F (-50 to +70°C)
	Ambient humidity	35% to 100%
Dial	Scale layout	Customer specified
Electrical	Number of switches	2 or 4
	Switch type	Magnetic blow-out
	Switch rating (AC)	3A @ 220 VAC/VDC
	Dielectric strength	2000 VAC for one minute



AKM OLR remote mechanical oil level indicators

Remote indicator

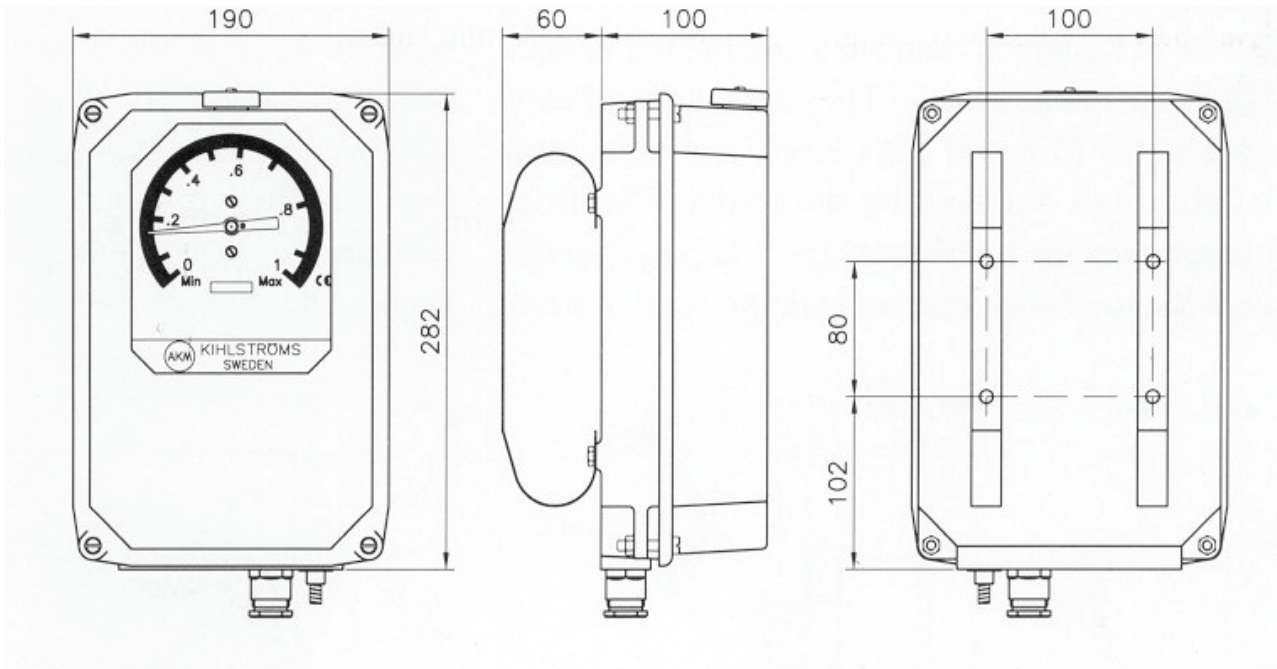

Flange assembly

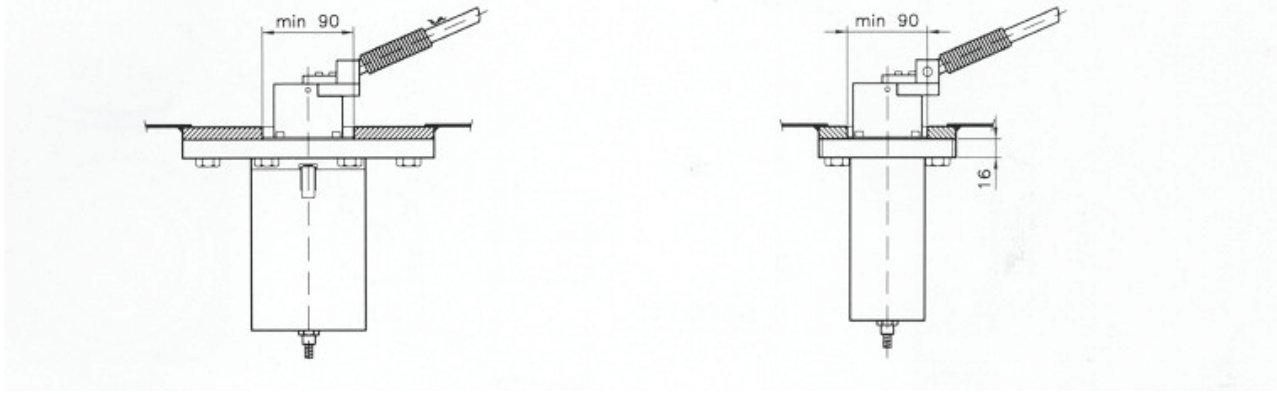

Circle flange

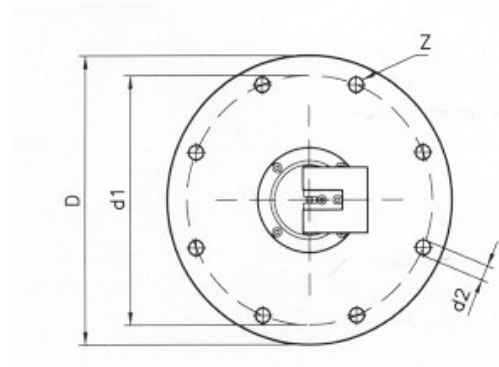

Square flange

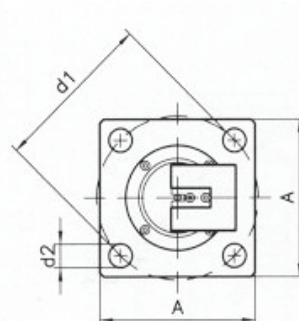

©2019 QUALITROL® Company LLC, an ISO 9001 system certified company. All rights reserved. Information subject to change without notice. All trademarks are properties of their respective companies, as noted herein. AP-L18-01A-02E.